

# INDUCTION HEATER SERIE

# DHI-190F HD



Operating and Maintenance Manual v. 2

**DAWELL CZ**  
INDUSTRIAL HEATING TOOLS

**CONTENT:**

1	INTRODUCTION.....	3
2	SAFETY INSTRUCTIONS .....	3
	2.1 Individual protection.....	3
	2.2 Danger of burns .....	3
	2.3 Risk of fire and explosion .....	4
	2.4 Gas fume hazards .....	4
	2.5 Electromagnetic field emissions .....	4
	2.6 Optical radiation .....	5
	2.7 Electrical risk.....	5
	2.8 Transport .....	5
3	CONNECTION .....	6
4	ENVIRONMENT .....	6
5	MAINTENANCE.....	6
6	REGULATIONS .....	6
7	WASTE MANAGEMENT.....	6
8	TECHNICAL PARAMETERS .....	7
9	DESCRIPTION OF DEVICE.....	8
	9.1 Main screen .....	9
10	PUTTING INTO OPERATION.....	9
11	DEVICE CONTROL.....	10
	11.1 Standby mode .....	12
12	INFORMATION DISPLAY .....	12
13	SETTING THE PARAMETERS .....	13
	13.1 Function „TIMER“ .....	14
	13.2 Functions Pre- and Post- Heating .....	15
14	INDUCTORS.....	17
	14.1 Replacing the heating inductor.....	18
15	COOLANT CHANGE.....	18
	15.1 Coolant.....	19
16	LIST OF ERROR MESSAGES .....	19
17	REMOTE CONTROL.....	20
	17.1 Activating the heating with the foot pedal.....	20
	17.2 Current loop control.....	20
	17.3 Temperature regulator control.....	21
	17.4 Bus RS-485 control.....	21
18	PICTOGRAMS .....	21
19	DEVICE BLOCK DIAGRAM .....	23
20	WARRANTY TERMS .....	25
21	WARRANTY SERVICE .....	25
22	USED DEVICE DISPOSAL .....	25
23	QUALITY CERTIFICATE .....	26
24	WARRANTY CERTIFICATE .....	27

## 1 INTRODUCTION

Dear customer, thank you for purchasing a product of DAWELL CZ s.r.o. We believe that you will be fully satisfied with our product and will choose us again in future. If you have any questions or comments, feel free to contact us via our web site or turn to your business representative.

Pursuant to this Manual, the first use of the equipment is the legal step whereby the user confirms with their free will that they have read this Manual properly, understood its meaning fully and are informed about all the risks.

## 2 SAFETY INSTRUCTIONS



This manual contains safety and operating instructions that must be followed for your safety. Read it carefully before using the equipment for the first time and keep it in a safe place for future reference. The latest version of the manual can be found on the manufacturer's website.

Read these safety instructions carefully before using or maintaining the equipment.



The manufacturer is not responsible for any damage or injury caused by failure to follow the instructions in this manual. Any modifications or maintenance not specified in this manual must not be performed. The appliance must only be used for heating ferrous materials in accordance with these instructions.

### 2.1 Individual protection



Persons with other metallic or electronic surgical implants are not allowed to work with this device and have to keep a safe distance of at least 1 m. Because of the contact currents, they should not approach or touch the heated parts. Consult a doctor and assess the risks before approaching the equipment.



When working with this device, do not wear any metal objects such as jewels, rings, watches, necklaces, identification plates, belt buckles, piercing or clothes with metal components such as metal rivets, buttons, zip fasteners, etc.



Always wear safety goggles or face mask when using this device.



Always use protective gloves with adequate resistance when working with the device.



Wear protective clothing when working with the equipment.

### 2.2 Danger of burns



The high temperatures produced by using this device may cause serious burns on contact with the heated part. Do not touch any objects located near the heating inductor unless you have checked that it has cooled down.

Make sure that jewellery and other metal parts do not come near the switched on inductor. They will heat up quickly and could cause burns.

## 2.3 Risk of fire and explosion



Do not overheat heated components and their surface with adhesives or similar surfaces. Do not place the equipment on or near flammable surfaces. Do not place equipment near combustible materials. Always keep a fire extinguisher near the equipment.



Do not use the equipment in explosive environment. Do not heat gas or other pressure vessels or containers containing flammable gases or liquids with the equipment and keep them well away from the induction heating equipment.

## 2.4 Gas fume hazards

Keep your distance from the equipment to avoid breathing in fumes.

If using the equipment in a confined space, ventilate the area or use an extractor to extract gases and fumes. If ventilation is inadequate, use a breathing unit. Make sure you are supervised by a qualified person when working. Check the quality of the air you breathe.

Heating certain materials such as paints, adhesives, fluxes, etc. can produce fumes and gases. Inhaling these fumes can be a health hazard and can cause death. Therefore, read the appropriate safety data sheets and instructions for heated materials such as metals and their finishes, adhesives, fluxes, paints, cleaners, corrosives, paint removers, etc.

Do not use the equipment on parts that are degreased or sprayed, the heat can react with fumes and can produce highly toxic gases.

Do not heat metals such as galvanized steel and metals coated with cadmium, lead, etc. with the equipment unless the surface has been removed prior to heating and only if the area is well ventilated or use an approved filtration unit. Foundry pieces and all metals containing the above-mentioned elements may produce toxic fumes when heated.

## 2.5 Electromagnetic field emissions



During use, the inductor generates a strong electromagnetic field that is not visible. The device is designed to minimise the risks from electromagnetic fields, but residual risks remain.

Recommended safe distance between the inductor and head or body of operator is at least 30 cm.

Never leave the inductor near the head or vital organs or wrap the induction heating cable around the body.

Nearby electro-magnetic fields generated by the device may adversely affect the operation of electronic devices located near the device during operation.

### 2.5.1 Dangerous zones of the electromagnetic field

Measurements made on DHI-190F HD according to EMF Directive 2013/35/EU

Yellow dashed - danger zone for head and body

Red continuous - danger zone for limbs

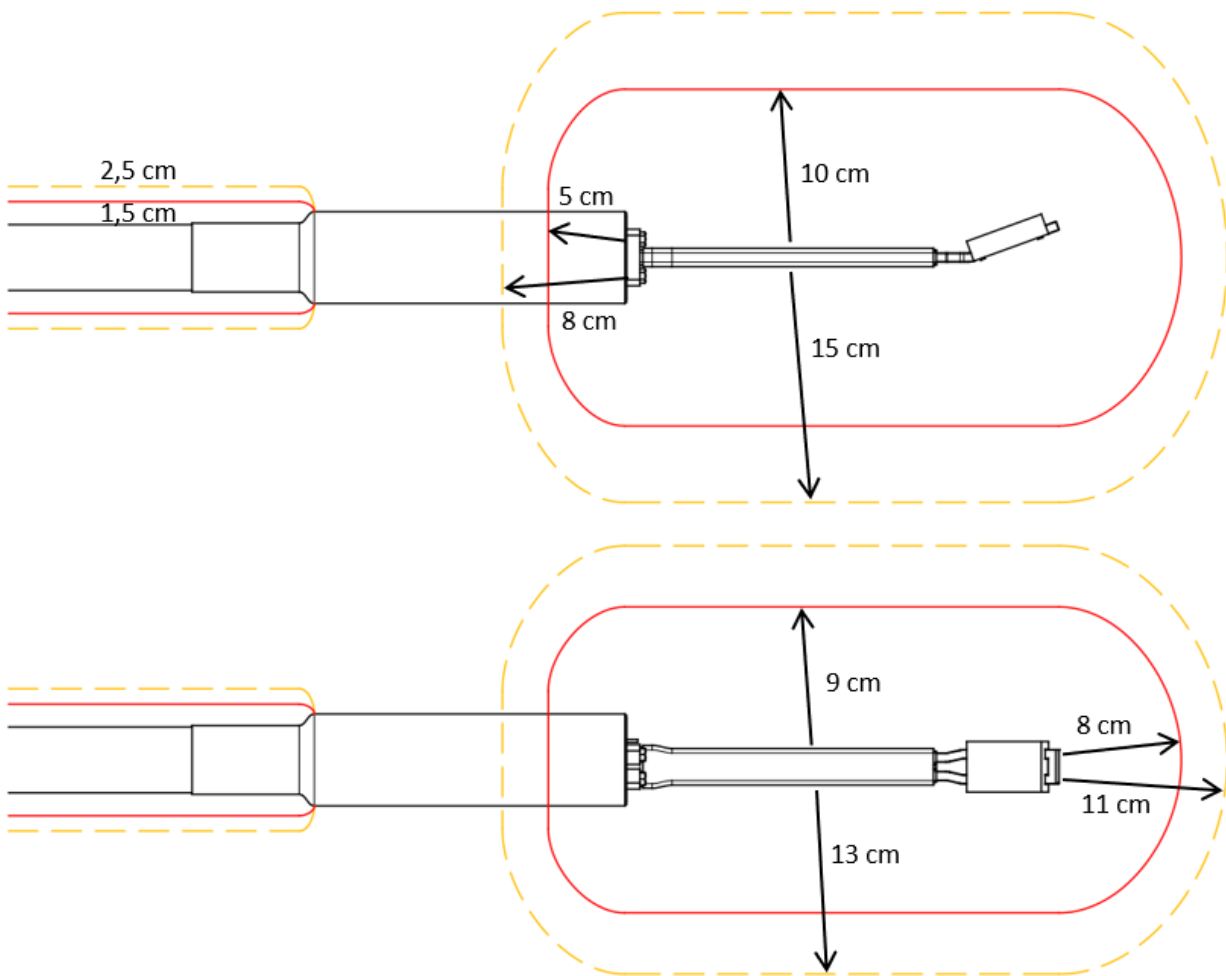

## 2.6 Optical radiation



Infrared and optical radiation is generated due to the heating of the workload.

## 2.7 Electrical risk



**WARNING!** Electrical hazard. Do not use the device if the device is damaged in any way, especially the power cord, the applicator lead or the mains plug. Electrical shock can cause serious injury or potentially fatal accidents..



**WARNING!** The device has safe touch currents of up to 35 kHz when operating on parts accessible to touch when using the protective cover of the connection terminals, which can cause an uncontrollable painful reaction due to the passage of high frequency current when interacting with tissue.

## 2.8 Transport



When moving the device, it must be in a vertical position.  
Do not use the power cord or applicator cable to move or lift the device.

### 3 CONNECTION



The device is a Class I appliance and must be connected to a grounded outlet.

The device is protected by a fuse.



These Class A, group 2 device is not intended for use in dwellings where the electricity is supplied from the public mains with a low-voltage source. Electromagnetic compatibility problems may arise in these areas due to interference and radio frequencies.

### 4 ENVIRONMENT

Operating temperature: 0 to +40 °C

Storage temperature: -10 to +55 °C

Humidity: ≤ 50% up to 40 °C, ≤ 90% at 20 °C

Altitude: up to 2000 m above sea level

### 5 MAINTENANCE



If the power cord or applicator cable is damaged, it must be replaced by the manufacturer or a qualified person to avoid danger.

Maintenance must only be carried out by a qualified person. An annual maintenance cycle is recommended. Warranty service may only be performed by a service technician trained and authorized by the manufacturer.



**WARNING!** Always disconnect the unit from the mains and wait at least 2 minutes before carrying out maintenance. High voltages are present inside the equipment and residual dangerous voltages may remain on the capacitors!

When performing maintenance, remove the cover and any excess dust inside the device. On this occasion, have a qualified person use a measuring instrument to check the electrical insulation, protective earth and connections of the device, including the applicator insulation!

Clean the surfaces of the device with a dry cloth. Do not use aggressive chemical cleaners, solvents or thinners.

Do not block the air supply to the device.

### 6 REGULATIONS



The equipment complies with European directives.

A certificate confirming that the device complies with European directives is available on request or on website of producer.

### 7 WASTE MANAGEMENT



Disposal of this product should be made at a suitable recycling facility. Do not dispose of it in normal municipal waste.

## 8 TECHNICAL PARAMETERS

Type	DHI-190	
Modell	DHI-190F HD 6M	DHI-190F HD 10M
Power supply requirements	3x 400 V	
Frequency	50/60 Hz	
Number of wires	3 phases + PE	
Rated input current	30 A	
Rated input power max	19 kW	
Output power max	13 kW	
Operating frequency	18-35 kHz	
Apparent output power	33 kVA	
Power cable length	5 m	
Applicator length	6 m	10 m
Coolant capacity	17.5 l	18 l
Coolant	DW-COOLANT-DHI	
Protective system	IP21	
Internal fuses	3x F32A, 1x T2A, 6.3x32, 500 V	
Dimensions (w x h x d)	540 x 960 x 840 mm	
Weight	96 kg	100 kg

## 9 DESCRIPTION OF DEVICE

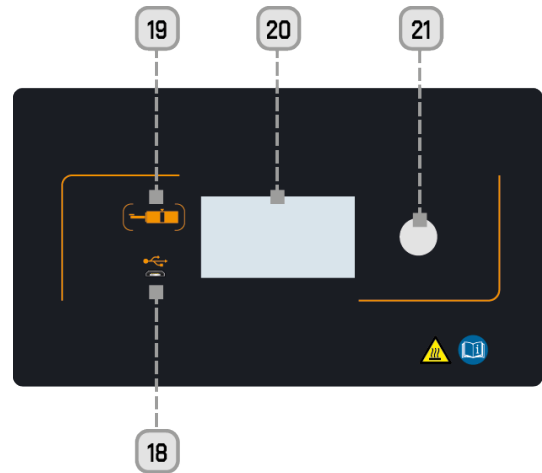







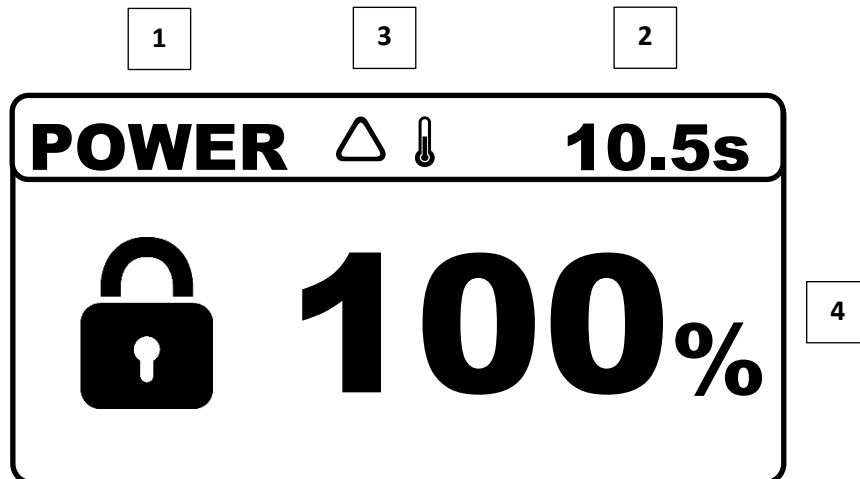



### Pos. Description

1	Handle
2	Induction burner cable
3	Connector – remote control
4	Connector – pedal
5	Control panel
6	Storage area
7	Control cable
8	Induction burner control button
9	Induction focus attachment
10	Cooling holes
11	Coolant level gauge
12	Mains switch
13	Front wheel brake
14	Grid power cable
15	LED indicator
16	Nameplate
17	Plug 3x 400 V <sub>AC</sub>
18	USB connector
19	Heating activation button Inductor change button
20	OLED
21	Encoder
22	Coolant funnel

## 9.1 Main screen



1. Parameter / screen name
2. Set / remaining timer value
3. Status icons
4. Parameter value

-  LOCK - device safety lock
-  HEAT - heating in progress
-  TIMER - timer
-  PRE-HEAT - preheating
-  PRE-TIMER-HEAT - preheating time
-  TIMER-POST-HEAT - post heating
-  PRE-TIMER-POST-HEAT - post heating time
-  WARNING
  -  FAN – fan failure or low fan speed
  -  VOLTAGE – approaching outside operating range
  -  TEMP LIMIT - approaching overheat/temperature power limitation.

## 10 PUTTING INTO OPERATION

1. Unpack the device and any accessories supplied and check that they are in good order and the device and the accessories are not damaged. If you find any defects, do not continue!
2. If an inductor is not installed in the process applicator, install it according to chapter **14.1 Replacing the inductor**.
3. Check that the tank is filled to the maximum. If not, unscrew the tank cap, insert the filler neck and fill the tank to the maximum with the special coolant.
4. Connect the device to a 3x 400 V socket and turn it on using the switch at the front of the device (12).
5. The cooling circuit venting is activated automatically (the letters „WATER FILLING“ flash on the display during this).  
If the machine has not been used for an extended period of time, place the applicator in an upright position with the inductor facing upwards during the watering phase to properly fill with coolant.
6. When filling the machine with coolant for the first time, it is necessary to top up the coolant several times. In this case, turn the unit off and return to step 3.
7. Put on the tank cap.
8. The device is ready to use.

## 11 DEVICE CONTROL

1. Connect the device to a 3x 400 V socket and turn it on using the main switch (12).



2. The device starts automatic watering of the cooling circuit. Wait for the process to finish.  
**Note:** The watering cycle can be paused by pressing the encoder.

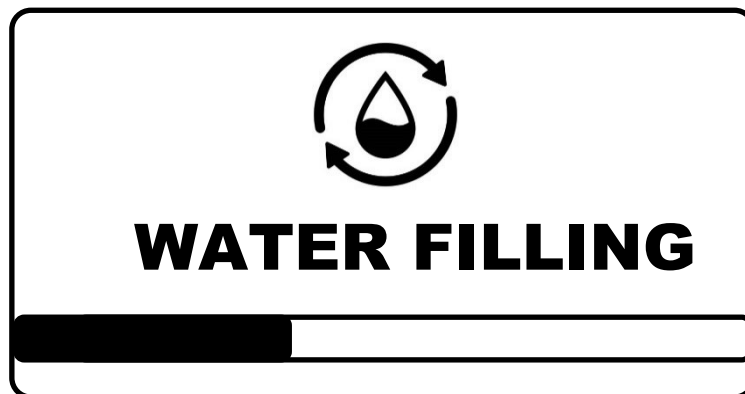

3. When finished, the main screen will appear. The device is ready for use.

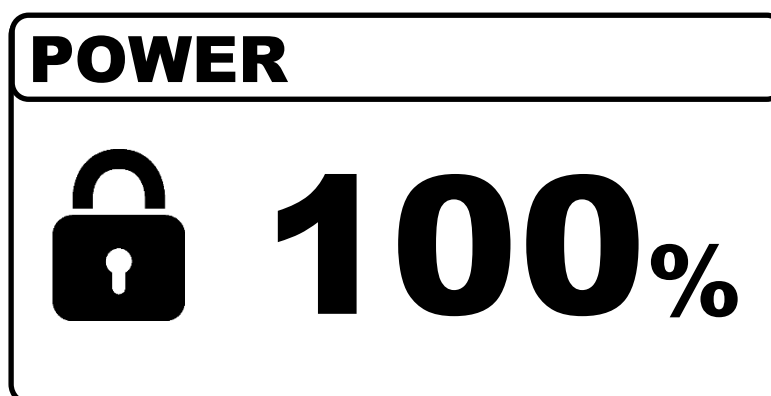

4. Before starting heating, the device must be activated by pressing the activation button (19) on the panel. The lock symbol will disappear on the display and the option to start heating by pressing the button on the applicator will be activated.

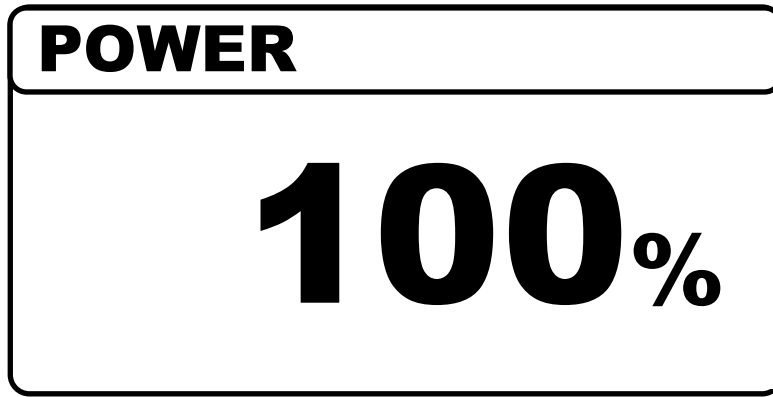

By turning the encoder you can set the desired heating power in percentage.

- Place the inductor (9) with the open part of the ferrite on the workpiece and then start heating by pressing the heating button on the applicator (8) or by pressing the pedal. Move the inductor smoothly over the area to be heated and do not leave it in one place for a long time to avoid overheating the material and the inductor.



The ongoing heating is indicated by a symbol  on the display and an LED light (15) on the applicator.

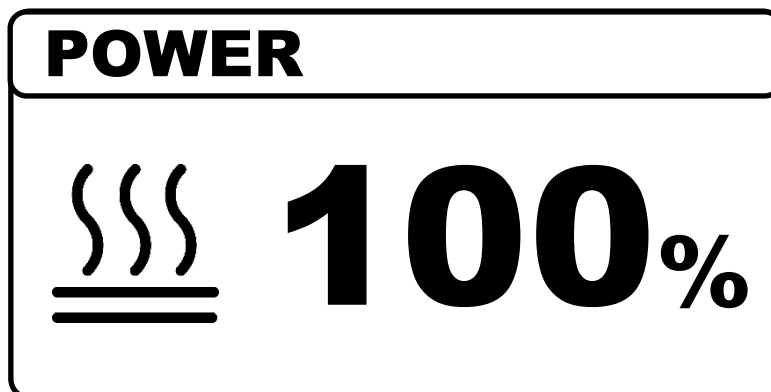

**Note:** The output can also be changed during heating.



Do not heat the same area for too long to prevent the heated material from melting. The heating is strong and fast and without the correct power setting, the material being heated may be damaged.

The equipment has been designed to minimize the risks caused by electromagnetic fields. Some residual risks remain and it is recommended that a safety distance between the inductor and the operator's head/body be maintained.

### 11.1 Standby mode

For safety reasons, after 5 minutes of inactivity, the option to start heating is deactivated and the device enters standby mode, which is indicated by the LOCK symbol on the display.

To activate the machine, press the heating activation button (19).

Within 15 minutes of locking, the machine can also be activated by pressing the button (8) on the applicator for 1 s, allowing the user to remain in the working position without having to walk to the machine.

## 12 INFORMATION DISPLAY

A short press of the encoder (21) in the main screen displays information with the operating parameters of the heater. Rotate the encoder to move through the items.

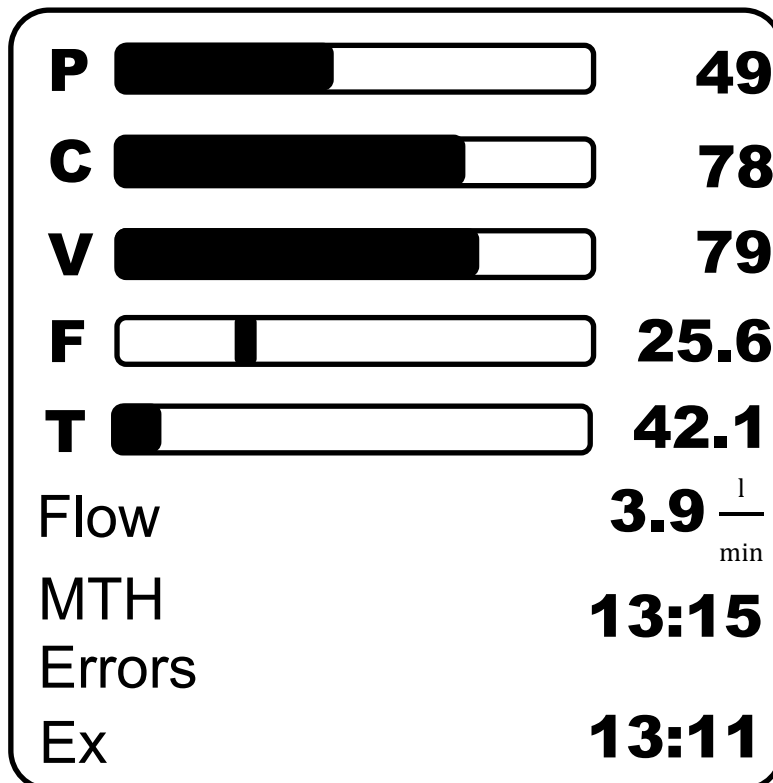

**Note:** Flashing of a parameter indicates the current power limit of the current heating process.

Meaning of parameters:

Parameter	Description
<b>P</b>	Output power in percent.
<b>C</b>	Output current in percent.
<b>V</b>	Output voltage in percent.
<b>Frequency</b>	Output frequency in kHz. The indicator should not approach the edges when heated.
<b>Temp.</b>	Coolant temperature in °C with display of cooling status indicator up to max. temperature.
<b>Flow</b>	Coolant flow rate in l/min.
<b>MTH</b>	Operating time in hours (hh:mm)
<b>Errors</b>	Displays the history of the last 4 errors that have occurred in the device.

## 13 SETTING THE PARAMETERS

Display the SETTING menu by long pressing the encoder (3 s). Rotate the encoder to select the desired parameter and confirm the selection by pressing the encoder. The selected parameter will flash and by rotating the encoder is set the desired value, then press the encoder again to confirm value. Exit the SETTING menu again by long pressing the encoder (3 s).

**Note:** If the parameter takes the value "---" it means that it is not available in the given configuration.

Timer	<b>10.5</b> s
Pre.Time	<b>1.5</b> s
Pre.Power	<b>50</b> %
Post.Time	<b>1.5</b> s
Post.Power	<b>30</b> %
Rmt.Control	<b>2T</b>
Comm.Addr.	<b>---</b>
Advance menu	

Meaning of parameters:

Parameter	Description
<b>Timer</b>	TIMER function: setting the time from 1 to 300 s activates the function, setting it to OFF deactivates it.
<b>Pre.Time</b>	PREHEATING function: Setting the preheating time from 1 to 300 s activates the function, setting it to OFF deactivates it.
<b>Pre.Power</b>	PREHEATING: Setting the preheating power in percentage.
<b>Post.Time</b>	POSTHEATING function: Setting the post heating time from 1 to 300 s activates the function, setting it to OFF deactivates it.
<b>Post.Power</b>	POSTHEATING: Setting the post heating power in percentage.
<b>Rmt.Control</b>	Setting the control for activating the preheating: 2T - button on the burner PED - via foot pedal PEA - via analogue input (0/4-20 mA) TEA - control via temperature controller MBUS - control via RS-485
<b>Comm.Addr</b>	Communication address for RS-485
<b>Advance menu</b>	Go to advanced menu

The advanced menu contains less used items. To return, long press the encoder (>3 s).

Back	
Heat.Lock	<b>20</b> min
Standby	<b>OFF</b>
Cooling	<b>STD</b>
Repl.coolant	<b>NO</b>
Bus Volt.	<b>524</b> V
In.Curr	<b>8.1</b> A
In.Curr.Max	<b>MAX</b>
Factory reset	<b>NO</b>
Firmware	

The following parameters are available:

Parameter	Description
<b>Back</b>	Return to the main settings menu
<b>Heat.Lock</b>	Heating start lockout time
<b>Stanby</b>	Standby time (cooling off)
<b>Cooling</b>	Cooling mode setting: STD (standard) / MAX (maximum output)
<b>Repl. coolant</b>	Activates coolant change mode
<b>Bus Volt.</b>	Internal DC voltage in Volts
<b>In. Curr</b>	Input current drawn in Amps
<b>In.Curr.Max</b>	Maximum input current draw limit (6 A - 30 A)
<b>Factory reset</b>	Restore factory settings
<b>Firmware</b>	Device version view

### 13.1 Function „TIMER“

The timer is a function that allows the heating to stop automatically after a certain (set) time. The function thus enables the dosing of the transferred energy (heat) into the material, e.g. for repeated spot heating to the required temperature.

The timer function is activated when the desired time is set in the TIMER parameter and is indicated on the display by the symbol and the set time. It is deactivated by setting to OFF.

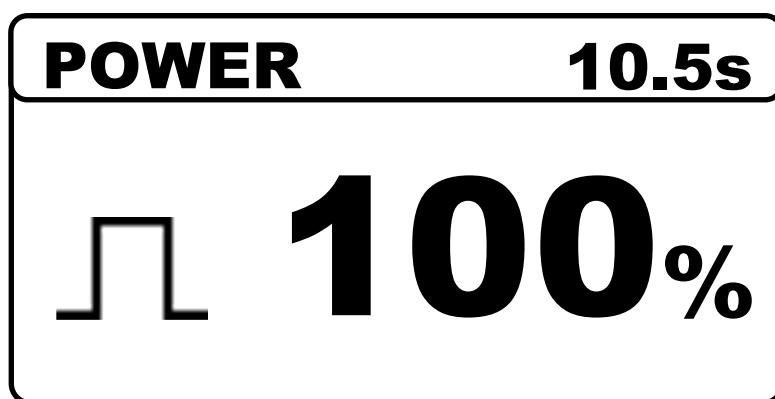

During heating, the display shows the bar graph and the time remaining until the heating is switched off. When the set time has elapsed, heating is automatically terminated, indicated by the disappearance of the heating symbol and the expiry of the countdown.

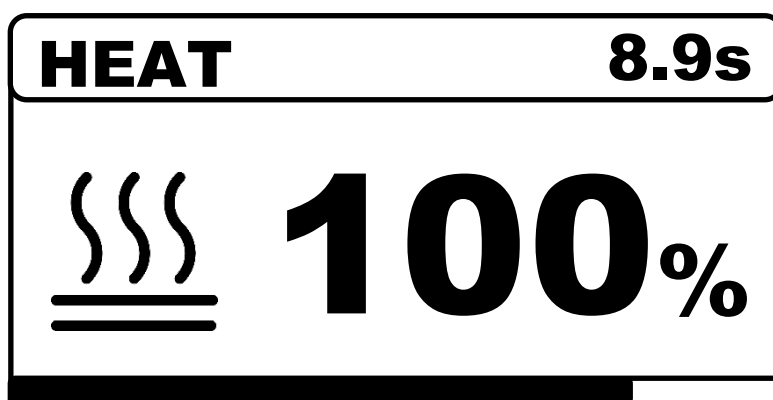

### 13.2 Functions Pre- and Post- Heating

The *Pre-Heating* function allows the automatic insertion of a user-set preheating phase, which is performed before the main heating cycle starts. The function is activated by setting the *Pre.Time* parameter to the desired non-zero value and the desired *Pre.Power* of this phase. Pre-Heating can be used, for example, to preheat the material and bring it to a lower temperature than the soldering temperature before starting the main soldering cycle.

Conversely, the *Post-Heating* function allows for the automatic insertion of a user-set heating phase, which is automatically executed after the main heating cycle is completed. It is activated similarly by setting the *Post.Time* and *Post.Power* of this heating phase. It is used for subsequent warming up or slower cooling of the heated material.

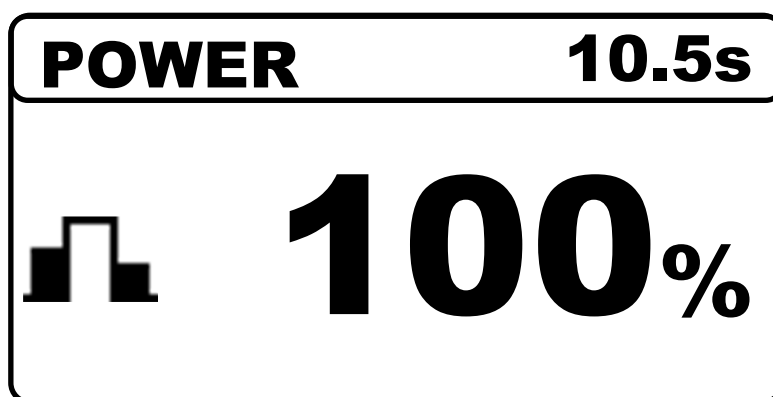

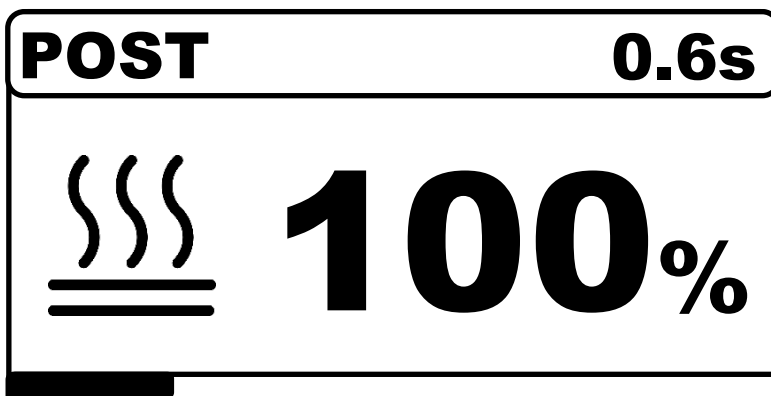
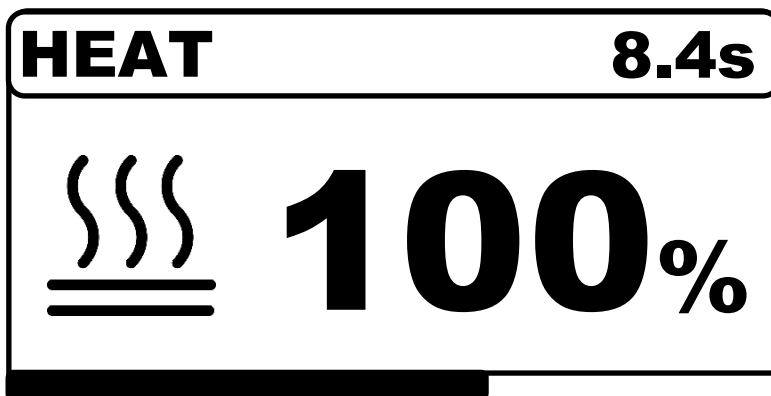
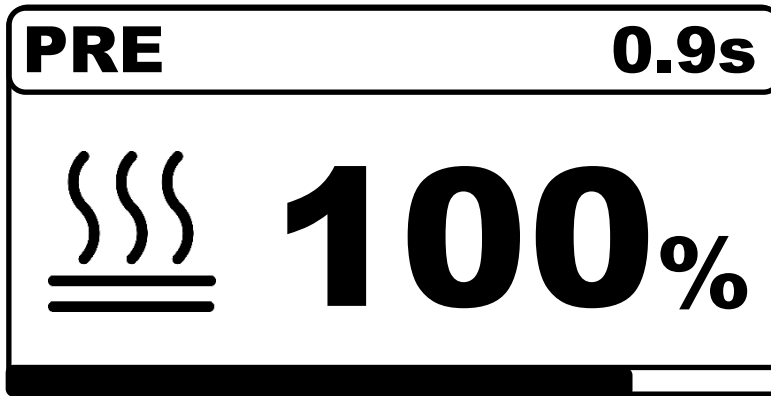

In the Pre- and Post- Heating phase, the segment inscription is displayed. The time on the top right counts down each section separately. The bar graph reads the total heating time.



## 14 INDUCTORS

DHI-190F HD comes standardly with the INDT-FE33-52 inductor.

Inductors and other accessories are optional and allow expanded heating options for different applications.

Inductor designation for DHI-190	
<b>INDT-FD38-18</b>	<b>INDT-FD33-52</b>
Focusing coil round 38 mm (83M-001)	Focusing coil rectangular 33x52 mm (83M-002)
	



**ATTENTION!** Use only the original accessories for the device! If non-original accessories are used, the manufacturer is not liable for any damage caused using unsuitable or non-original accessories.

Heated metal radiates heat into the inductor and the inductor is highly exposed to heat. Excessive heating of the inductor (e.g. by heating to a high temperature, leaving the inductor on the molten material, etc.) shortens its life and it is up to the user to avoid such excessive heating.

When the metal is dark red the temperature is below 850 °C, when it turns bright red to orange the temperature exceeds 1000 °C and when it turns white the temperature exceeds 1200 °C.

### Position of the heating button

The control button must be located at least 35 mm from the front edge of the applicator.



### 14.1 Replacing the heating inductor

It is recommended to replace the inductor when the device is switched off, however, it is possible to do it according to the following procedure with the device switched on:

1. Long press the activation button (19) until "REPLACE INDUCTOR" appears on the display.

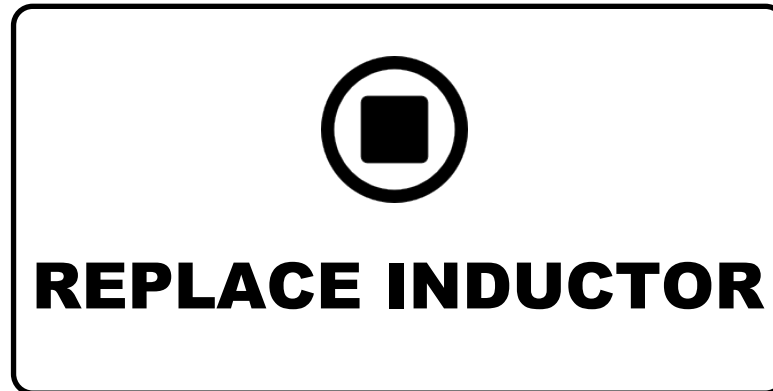

2. Grip the handle so that it is vertical with the attachment upwards and above the top edge of the main unit, to avoid liquid leakage.
3. Unscrew the heating inductor attachment using a suitable tool.
4. Clean the contact surfaces on the applicator and inductor.
5. Check that sealing rings are present on the applicator to prevent coolant leakage.
6. Attach the desired inductor, screw it in lightly and then tighten it (tightening torque 2.5-3 Nm).
7. Long press the activation button (19) to activate the cooling circuit watering and wait for it to complete.  
**Note:** If, for example, incorrect installation causes a coolant leak, press the activation button (19) or the encoder (21) to pause the watering process, correct the problem and press again to complete the cycle.
8. When the watering is complete, the unit is ready for use.

### 15 COOLANT CHANGE

It is recommended to change the coolant regularly (once a year) to prevent degradation and damage to the heater. Coolant change procedure:

1. From the SETTING menu, select ADVANCE MENU, then REPLACE COOLANT. The screen will appear:

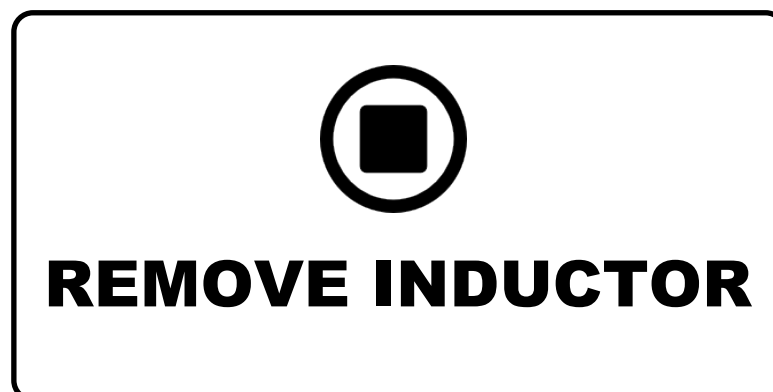

**Note:** The fluid change process can be cancelled by long pressing the activation button (19).

2. Unscrew the inductor (9) from the process applicator. Then place the applicator in a suitable container and allow the coolant to flow out of it.
3. Press and hold the button on the applicator (8) until the coolant flows out.

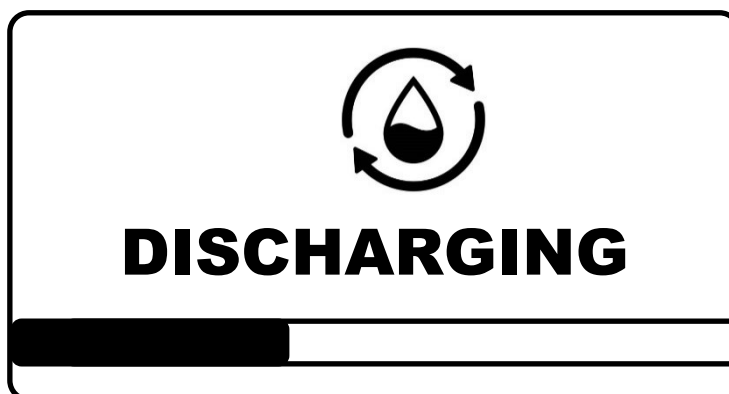

The discharge can be repeated until the device is empty.

4. For maximum release, then tilt the device backwards at an angle of approx. 30° (raise the handle of the device). Press and hold the button on the applicator (8) until the remaining coolant is drained.
5. Switch off the device.
6. Reinstall the inductor back onto the process applicator as described in "Replacing the Inductor" and proceed to fill with new coolant as described in „PUTTING INTO OPERATION“.

### 15.1 Coolant



Use only the coolant approved by the manufacturer. Use of improper coolant may damage the equipment and cause electric shock. The manufacturer is not responsible for any damages if improper coolant is used.

Attribute	Value
pH (for 20 °C)	7.5 (100 %)
Relative density	≈ 1.01

**Note:** For safe handling and use of coolant, follow the coolant manufacturer's instructions. Refer to the manufacturer's website for the Safety Data Sheet and more information.

## 16 LIST OF ERROR MESSAGES

If a device error occurs, the display will show its code:

Error code	Error description	Possible causes
E1	Grid undervoltage	Undervoltage in the power supply network, or failure of one of the phases.
E2	Grid overvoltage	Overvoltage in the power supply network.
E3	Input overcurrent	Error due to short-term overload.
E4, E5	Output overcurrent	Error due to connection of an incorrect inductor, short circuit due to insulation damage, etc.
E6	Overload	Error due to an unexpected change in the nature of the workload
E7	Too low frequency	Minimum operating frequency exceeded, e.g. due to connection of too large an inductor.
E8	Too high frequency	Maximum operating frequency exceeded, e.g. due to connection of too small inductor.
E9, E11	Resonance circuit and frequency control error	Error due to connection of a non-original heating inductor or short-circuiting of the inductor due to insulation damage

<b>E12</b>	Cooling error	Cooling circuit failure, coolant flow not detected. No coolant, pinched or blocked hose, etc.
<b>E14 – E18</b>	Device overheating	Overheating of the equipment. E.g. air flow restriction, dust blockage in cooling exchangers, prolonged overloading of the unit, etc.
<b>E20 – E256</b>	Device servicing errors	Errors in the instrument hardware, please contact service.

Errors E3,4,6,7,8,9,11,12 are resettable by the user by pressing burner control button or encoder.  
Errors E1,2,14,15,16,17,18 reset automatically after the error condition is resolved.

The machine is equipped with several protective elements especially against electrical and thermal damage. In case of an error, the heating does not work.

If the thermal protection is activated, simply wait until the aftercooling phase is over.

If error E12 occurs, first check that there is sufficient coolant in the tank and that there is no leakage. Visually inspect the process applicator line for breaks or pinching.

If other errors occur, turn the unit off with the main switch and turn it back on.

## 17 REMOTE CONTROL

The remote control is activated in the SETTING menu, parameter *Rmt.Control*.

Mode	Description
<b>2T</b>	Remote control off. Heating is started by a button on the burner.
<b>PED</b>	Heating is activated by the connected foot switch.
<b>PEA</b>	Heating control via 0/4-20 mA current loop.
<b>TEA</b>	Activation of the control via the temperature controller.
<b>MBUS</b>	Remote control via RS-485 bus

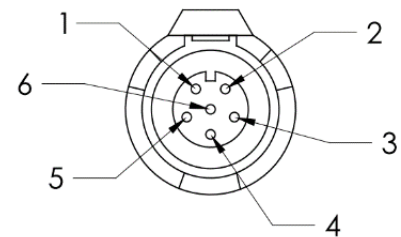

The remote-control circuitry is not galvanically isolated from the internal circuits and is connected to ground, therefore galvanically isolated transducers must be used when connecting the heater to the control systems to prevent damage to the equipment. **If this is not observed, the manufacturer will not be liable for any damage.**

### 17.1 Activating the heating with the foot pedal

The heating can also be activated using the foot pedal. Connect the foot pedal to the PED connector (see DESCRIPTION OF DEVICE, position 4) and set the "*Rmt.Control*" parameter to "PED" in the SETTING menu.

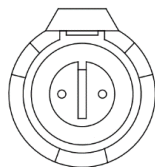

Pin	Description
<b>1</b>	GND (0 V)
<b>2</b>	NO contact

### 17.2 Current loop control

The heating output can be controlled remotely using a **0/4-20 mA** current loop.

Connect the control system to the RMT connector (see 9 DEVICE DESCRIPTION, position 3) and set the parameter "*Rmt.Control*" in the SETTING menu to "PEA". The connector wiring (device view) is as follows:

Pin	Designation of individual pin functions for 6 pin connectors		
1	GND	Joint	Common ground 0 V
2	0/4-20 mA	Access	Positive input of the current loop (relative to GND).
3	HEAT	Output	0 mA - off; 4-20 mA - on with continuous power control from min (4 mA) to 100% (20 mA)
4	OK	Output	Active heating indication (NO contact, type OC, max. 24 V, 100 mA)
5	12 V	Power	Device readiness signal (NO contact, type OC, max. 24 V, 100 mA)
6	SH		Power supply 12 V, max. 0.5 A

### 17.3 Temperature regulator control







This remote-control mode is designed to control the heating to a set temperature using the supplied temperature controller, which can be simply connected to the RMT connector and activating by setting the "Rmt.Control" parameter to "TEA" in the SETTING menu. Set the desired temperature or temperature profile on the controller and activate the heating by pressing the button on the burner.















### 17.4 Bus RS-485 control

Activates basic heating control via RS-485 bus. To activate, set the "Rmt.Control" parameter in the SETTING menu to "MBUS".

Pin	Description	
1	GND	Common grounding
3	RS485B	Communication
4	RS485A	Communication
5	12 V	Power supply 12 V / 0.5 A
6	SH	Shielding

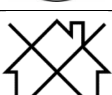
## 18 PICTOGRAMS

	Link to instructions for use
	General command mark
	No entry for persons with active implanted cardiac devices
	No entry for persons with metal implants
	No metal objects or watches
	General warning sign
	Warning; Hot Surface

	Warning: Flammable material
	Warning: Explosive material
	Warning: Non-ionizing radiation
	Warning: Magnetic field
	Warning: Optical radiation
	Warning: Electricity
	Wear eye protection
	Wear protective gloves
	Wear protective clothing
	Earthing (for protection)
	Not to be used in residential areas.
	The device complies with the European directives.
	Manufacturer participates in packaging recovery contributing to the global system of sorting, selective collection, and recycling of packaging waste.
	This hardware is subject to waste collection. Do not throw out in a domestic bin!

# 19 DEVICE BLOCK DIAGRAM

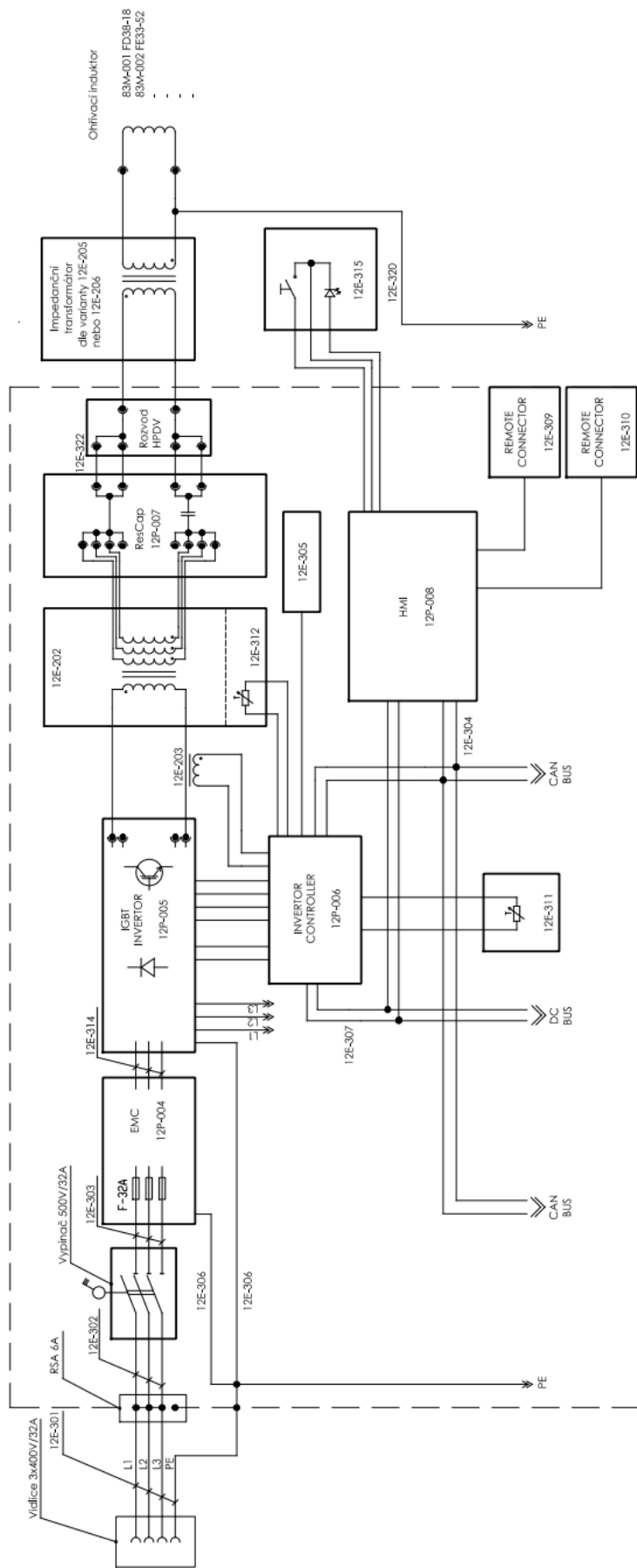

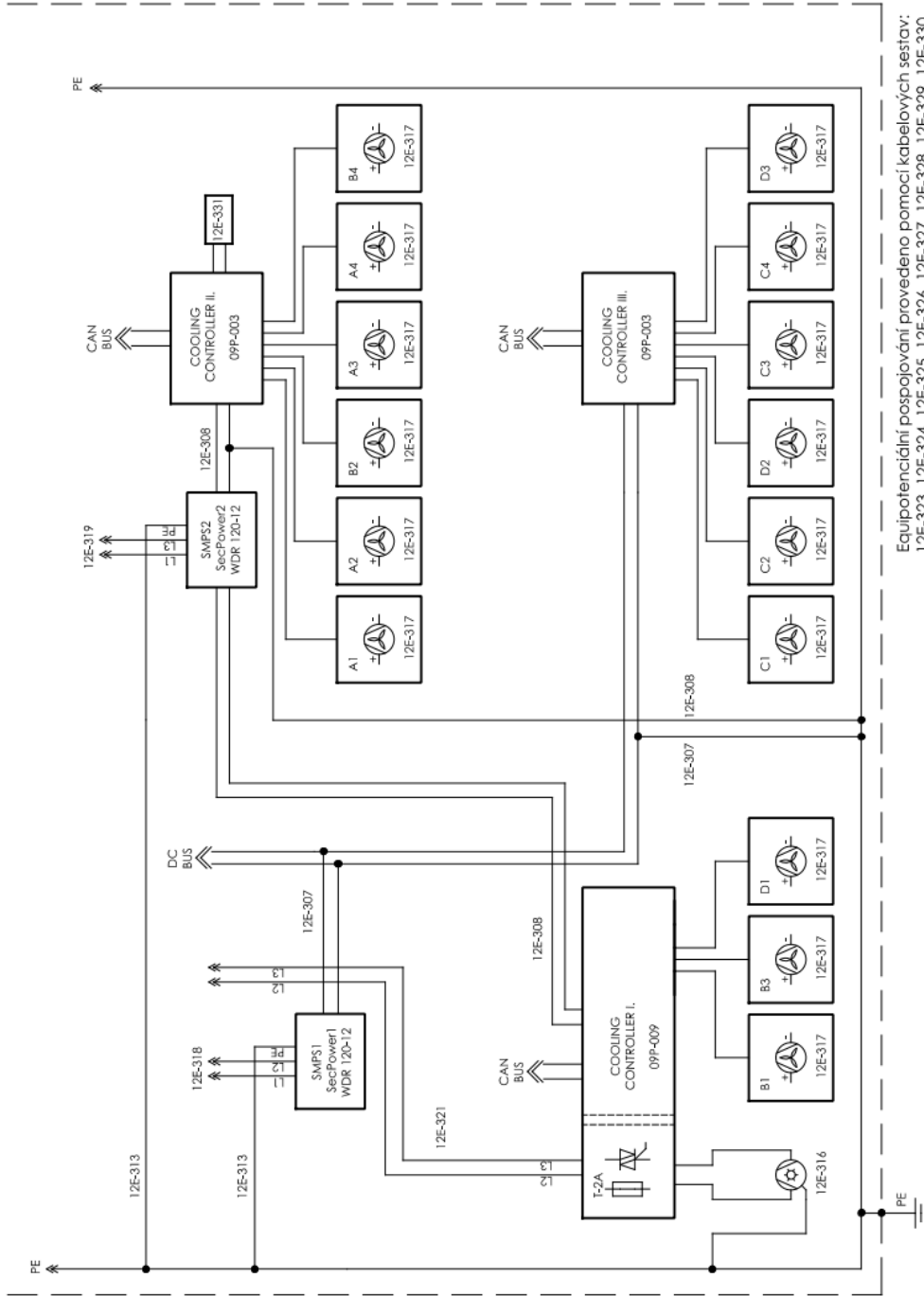

Equipotenciální pospojování provedeno pomocí kabelových sestav:  
 12E-323, 12E-324, 12E-325, 12E-326, 12E-327, 12E-328, 12E-329, 12E-330

## 20 WARRANTY TERMS

1. Unless otherwise stated, the warranty period for the devices is set by the manufacturer to 12 months from the date of sale to the buyer. The warranty period for the induction burner is 6 months. Consumable parts such as attachments, coils, etc. are covered by a warranty period of 3 months.
2. When claiming warranty repairs, it is necessary to present the warranty certificate, which is valid only if it bears the date of sale, the serial number, the stamp of the relevant shop and the signature of the seller, who hereby confirms the proper demonstration and explanation of the functions of the product.
3. The warranty period is extended by the time the power supply is under warranty repair. If no defect covered by the warranty is found during the repair, the costs associated with the performance of the service technician shall be borne by the owner of the power supply.
4. Warranty service applies to defects arising within the warranty period due to demonstrably defective design, faulty workmanship or unsuitable material. Such defects will be repaired free of charge by the manufacturer. Complaints shall be made by the user to the manufacturer of the power supply, the place of performance being the manufacturer's registered office.
5. The warranty does not cover defects caused by improper handling, overloading, use of incorrect accessories or tampering, natural wear and tear, or damage during transport. Damage caused by lack of care or neglect of maintenance, failure to comply with the regulations specified in the instructions, use of the machine for a purpose for which it is not intended and overloading of the machine, even if temporary, are not considered as defects.
6. The warranty is void if the user makes unauthorized modifications or changes to the power supply, if the power supply is connected incorrectly or if the power supply has been operated in violation of the technical conditions.
7. In no event shall the manufacturer be liable for consequential damages caused using the power supply. In no event shall the manufacturer's liability under this warranty exceed the cost of the power supply.
8. Only original manufacturer's parts must be used for maintenance and repair of the machine in accordance with their instructions for use.

## 21 WARRANTY SERVICE

1. Warranty service may only be performed by a service technician trained and authorized by the manufacturer.
2. Before performing warranty repair, it is necessary to check the machine data: date of sale, serial number, type of machine. In case the data does not comply with the conditions for the recognition of warranty repair, e.g. expired warranty period, improper use of the product contrary to the instructions for use, etc., it is not a warranty repair. In this case, all costs associated with the repair shall be borne by the customer.
3. In case of recurrence of the same defect on the same machine and part, consultation with the manufacturer is necessary.

## 22 USED DEVICE DISPOSAL



These devices are built using materials that contain no toxic substances or poisonous to the user. Dispose of the discarded device using a collection point intended for collection of used electric equipment. Do not dispose of the used device as ordinary waste.



The company is registered in the ASEKOL joint recollection system (under manufacturer reference number 04499/16-ECZ) and finances electrical waste management itself. This symbol on products and/or in product documentation means that used electric and electronic products must not be added to ordinary municipal waste.

## 23 QUALITY CERTIFICATE

Manufacturer: **DAWELL CZ s.r.o.**  
Budischowského 1073  
Třebíč 674 01  
Czech Republic

Product type:  DHI-190F HD 6M  DHI-190F HD 10M

Serial number: .....

Final inspection date: .....

Reviewed by: .....



**DAWELL CZ s.r.o.**

Budischowského 1073,

674 01 Třebíč

Czech Republic

Email: [sales@dawell.cz](mailto:sales@dawell.cz)

**[www.dawell.cz](http://www.dawell.cz)**