





MARTE 50

 **DESCRIZIONE**
Portata massima 50 kg.
Rotazione con motore a corrente continua.
Inclinazione manuale.

 **DESCRIPTION**
Maximum load 50 kg.
Slewing by DC motor.
Manual tilt.

 **BESCHREIBUNG**
Maximale Tragfähigkeit 50 kg.
Rotation mit Gleichstrommotor.
Kippung manuell.

 **DESCRIPTION**
Portée max 50 kg.
Rotation avec moteur à courant continu.
Inclinaison manuelle.

 **DESCRIPCIÓN**
Capacidad máxima 50 kg.
Rotación por motor de corriente continua.
Inclinación manual.



Tipo motore	L mm	W mm	H mm	Fø mm	volt	rpm	Portata / Load / Portee / Tragkraft / Capacidad		kg
							Horizontal kg	Vertical kg	
DC	170	170	227	150	24	0,5-6	50	10	6

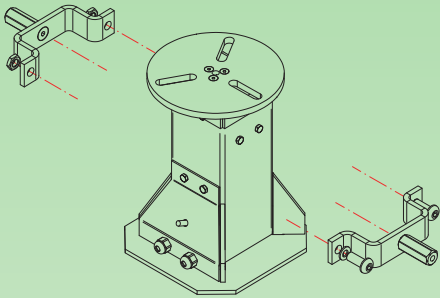

N° OPERAZIONE
1

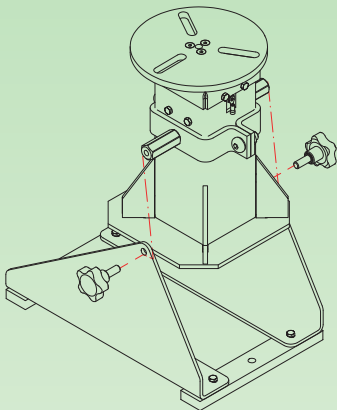
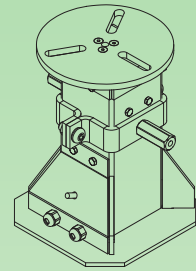

N° OPERAZIONE
2

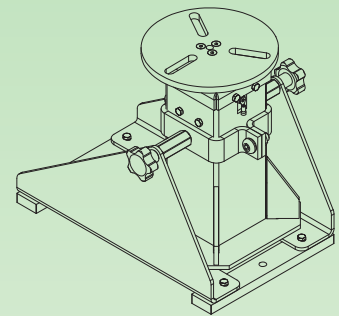

N° OPERAZIONE
3

