



PIPE EQUIPMENT SPECIALISTS

# PREP 8 PIPE BEVELLING 2" to 8"



SCAN QR CODE  
TO WATCH VIDEO





# PREP 8

Portable Pipe Beveling Machine

**RANGE: 50 - 211mm i/d / 2 - 8" i/d**

- **Functions:** External beveling / internal beveling / elbow and fittings beveling / facing / counter-boring / weld removal / J-prepping / compound bevels
- **Materials:** Any kind of steel and exotic alloy
- **Power:** Pneumatic or electric (110v or 220v)

One of our most powerful and popular i/d locking, in-line feed end prep machines. This is mainly due to its impressive 2 - 8" working range and unrivalled power. The PREP 8 is a portable, one man operation machine, its power to weight ratio, and offset 4-jaw tool holder (chuck) allows use of up to 4 insert or formed tools to enables simultaneous external, internal beveling of even the heaviest wall pipe. The PREP 8 is a real workhorse. Its size, power, and functionality, make it extremely popular in high volume heavy duty beveling applications, on site, or in the workshop.



## FEATURES AND ADVANTAGES

The PREP 8 is torque reactive. This means that the pipe or tube does not have to be fixed to be bevelled, making it particularly useful on-site, in maintenance and repair situations. This is due to the design and strength of the thru shaft system that locks to the bore of the pipe.

The jaw system itself consists of 3 equilateral positioned machined jaw segments, retained and locked on an inner, 'grooved' expansion shaft. These grooves keep the jaws held securely in position, unlike other systems that use a metal or rubber bands for jaw retention. As the expansion nut is tightened, the jaws expand, locking tightly, and square to the bore of the pipe.

The machine body is CNC machined out of solid aluminum and nickel plated. This ensures strength and leads to precise tolerances on all components, resulting in a stable heavy duty machine that does not move under load, we also ensure all components are treated utilising the latest technologies to ensure durability.

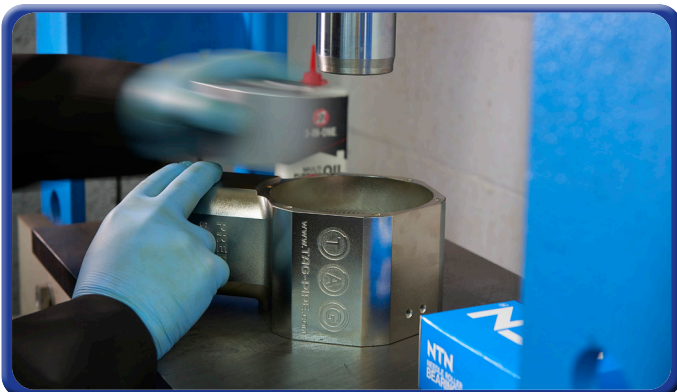

# POWER OPTIONS:

## PNEUMATIC



PART NO. TP8P

## ELECTRIC



PART NO. TP8E110 / TP8E220

# ACCESSORIES AND OPTIONS:

## ELBOW / FITTINGS SHAFT



PART NO. TP8ESK

## AUTO LOCK

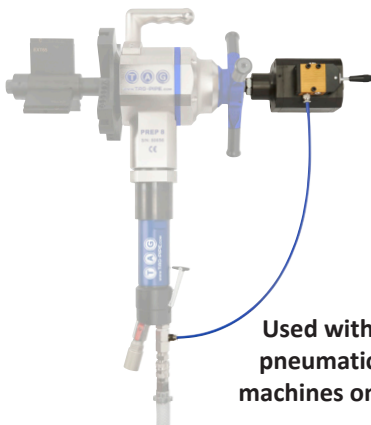

PART NO. TP8ALD

## RATCHET HANDLES



PART NO. TP8RHK

## FILTER LUBRICATOR



PART NO. AFL1



## PREP 8 TECHNICAL FEATURES

DESCRIPTION	MEASUREMENT	PNEUMATIC	ELECTRIC
Part Number	n/a	TP8P	TP8E110 / TP8E220
Locking tube range	mm (i/d)	50 - 211	50 - 211
Locking tube range	inch (i/d)	2 - 8"	2 - 8"
Idle speed	rpm	5 - 52	5 - 34
Torque	N m	265	280
Length of axial feed	mm	40	40
Max operating temperature	°C	55	55
Max acoustic radiation	dB	75	75
Pneumatic motor power	hp	1.85	n/a
Air consumption	cfm / l/min.	50 / 1400	n/a
Air working pressure	psi / bar	90 / 6.5	n/a
Air hose connection	inches	¾"	n/a
Electric motor power	watt	n/a	1900
Voltage	volt	n/a	110 or 220
Frequency	Hz	n/a	50 / 60
Unit weight	kg / lbs	25 / 55	26 / 57
Packing dimensions	mm	830 x 780 x 250	830 x 610 x 250
Packing weight	kg / lbs	55 / 121	54 / 119

*Our group policy is one of continuous improvement. Products and data tables are subject to change or vary from those illustrated.*

- All units are supplied complete with all gripping segments to cover the full range of the machine. Service tools, drawings, instruction manual and warranty certificate are also supplied as standard.
- Each machine is supplied with a protective custom built metal box.
- Pneumatic machine must be used with filter lubricator and oil - use without will void warranty.



### DIMENSIONS

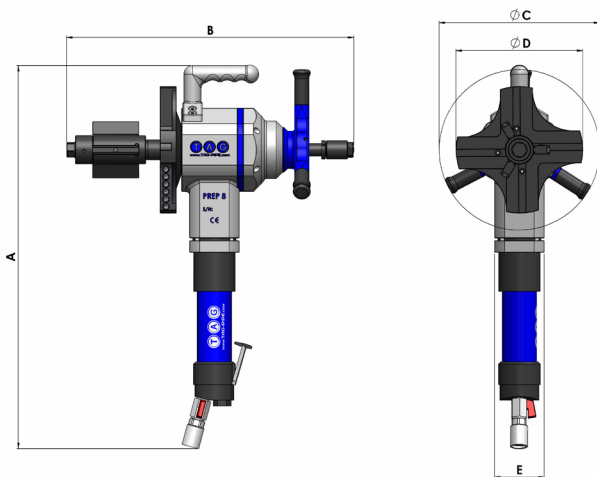

DIM	PNEUMATIC	ELECTRIC
A	670mm	700mm
B	520mm	520mm
∅C	278mm	278mm
∅D	220mm	220mm
E	86mm	90mm

### EXAMPLES OF COMMON CUTTING TOOLS

#### FORMED TOOLS

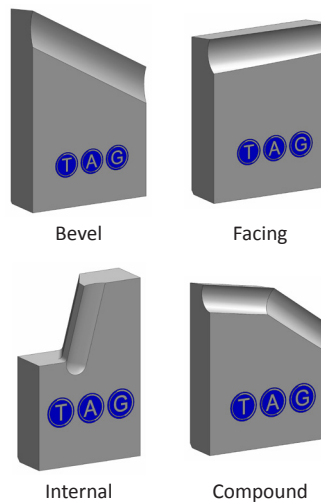

#### HOLDER / INSERT

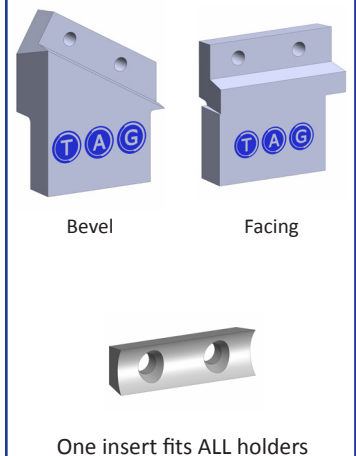

***All shapes, sizes and angles available***



SPECIALIZED FABRICATION EQUIPMENT GROUP

# Global Locations:



## UNITED STATES HEAD OFFICE - HOUSTON

SPECIALIZED FABRICATION EQUIPMENT GROUP

4433 South Drive,  
Houston,  
Texas 77053, USA

Tel: +1 713 747 8502

E-mail: [sales@sfe-brands.com](mailto:sales@sfe-brands.com)

## INTERNATIONAL HEAD OFFICE - FRANCE

SPECIALIZED FABRICATION EQUIPMENT GROUP

330B Route de Portes Les Valence,  
ZI les Bosses,  
26800 Etoile-sur-Rhône, France

Tel: + 33 (0) 475 575 070

E-mail: [sales-int@sfe-brands.com](mailto:sales-int@sfe-brands.com)

### SFE UNITED KINGDOM

SPECIALIZED FABRICATION EQUIPMENT GROUP

Unit 15 & 16 Grendon Industrial Estate,  
Grendon Underwood, Aylesbury,  
Buckinghamshire, HP18 0QX England

Tel: +44 (0)1869 324 144

E-mail: [sales-uk@sfe-brands.com](mailto:sales-uk@sfe-brands.com)

### SFE GERMANY

SPECIALIZED FABRICATION EQUIPMENT GROUP

Ostmarkstrasse 15,  
76437 Rastatt,  
Germany

Tel: +49 (0)7222 9355100

E-mail: [sales-germany@sfe-brands.com](mailto:sales-germany@sfe-brands.com)

### SFE KINGDOM OF SAUDI ARABIA

SPECIALIZED FABRICATION EQUIPMENT GROUP

Warehouse No: EM16-10, Air Base Determinant,  
Industrial supply scheme, Ash Shulah, Dammam  
34264, Saudi Arabia

Tel: + 966 50 515 8196

E-mail: [sales-ksa@sfe-brands.com](mailto:sales-ksa@sfe-brands.com)

### SFE MIDDLE EAST

SPECIALIZED FABRICATION EQUIPMENT GROUP

Shams Freezone  
Sharjah

United Arab Emirates

Tel: +971 (0)50 217 1376

E-mail: [sales-me@sfe-brands.com](mailto:sales-me@sfe-brands.com)

### SFE INDIA

SPECIALIZED FABRICATION EQUIPMENT GROUP

Plot No. PAP 3, D 3 Block,  
Chinchwad, Pune 411 019

Mob: +91 90 1102 4332

Mob: +91 95 5258 4361

E-mail: [sales-india@sfe-brands.com](mailto:sales-india@sfe-brands.com)

### SFE LATIN AMERICA

SPECIALIZED FABRICATION EQUIPMENT GROUP

4433 South Drive,  
Houston,  
Texas 77053, USA

Tel: +1 713 747 8502

E-mail: [sales-latam@sfe-brands.com](mailto:sales-latam@sfe-brands.com)

### SFE SOUTH KOREA

SPECIALIZED FABRICATION EQUIPMENT GROUP

102 - 1301 Bucheon Technopark III  
421 - 742 Gyeonggi-do-seoul, Taehan-min'guk  
South Korea

Tel: +82 32 624 2870

E-mail: [sales-asia@sfe-brands.com](mailto:sales-asia@sfe-brands.com)

### SFE VIETNAM

SPECIALIZED FABRICATION EQUIPMENT GROUP

Emerald Block A, No.2, Road N4,  
Son Ky Ward, Tan Phu District,  
Ho Chi Minh, Vietnam

Tel: +84 91 951 70 18

E-mail: [sales-vietnam@sfe-brands.com](mailto:sales-vietnam@sfe-brands.com)

### SFE CHINA

SPECIALIZED FABRICATION EQUIPMENT GROUP

1208, 12F, #D 7001 Zhongchun RD  
Minhang District  
Shanghai, China

Tel: +86 215 429 1891

E-mail: [sales-china@sfe-brands.com](mailto:sales-china@sfe-brands.com)

Copyright © 2022 Specialized Fabrication Equipment Group, All rights reserved.

## OUR BRANDS

